

**ARMY**                      **TM 11-6625-667-12**  
**NAVY**                      **NAVAIR 16-30APM-123-1**  
**AIR FORCE**                      **TO 33A1-3-367-1**

---

**TECHNICAL MANUAL**

**OPERATOR AND ORGANIZATIONAL MAINTENANCE MANUAL**

**TEST SET, TRANSPONDER**

**AN/APM-123[V] 1 [FSN 6625-948-0071]**

**AN/APM-123[V] 2 [FSN 6625-948-0077]**

**AN/APM-123[V] 3 [FSN 6625-948-0076]**

---

**HEADQUARTERS, DEPARTMENT OF THE ARMY**

**JUNE 1974**

**WARNING**  
**HIGH VOLTAGE**

Be careful when working near the 115-volt ac power connections. Serious injury or death may result from contact with these terminals.

**WARNING**

When a 115-volt ac 400 Hertz power source is to be used and the transponder to be tested is installed in an aircraft, connect test set to transponder before connecting test set power cable.

CHANGE }  
No. 3 }

DEPARTMENTS OF THE ARMY,  
THE NAVY, AND THE AIR FORCE  
WASHINGTON, D.C., 28 March 1977

**Operator's and Organizational Maintenance Manual  
TEST SET, TRANSPONDER**

**AN/APM-123(V)1 (FSN 6625-948-0071)  
AN/APM-123(V)2 (FSN 6625-948-0077)  
AN/APM-123(V)3 (FSN 6625-948-0076)**

TM 11-6625-667-12/NAVAIR 16-30APM-123-1/TO 33A1-3-367-1, 4 June 1974, is changed as follows:

1. New or changed material is indicated by a vertical bar.
2. Remove and insert pages as indicated below:

*Remove*  
✓ i and 1-0  
✓ 1 through 1-2.1  
✓ 2-5 and 2-6  
✓ 2-9 and 2-10  
: 2-13 and 2-14

*Insert*  
i and 1-0  
1-1 through 1-2.1  
2-5 and 2-6  
2-9 and 2-10  
2-13 and 2-14

3. File this change sheet in the front of the publication for reference purposes.

By Order of the Secretary of the Army:

Official:  
PAUL T. SMITH  
*Major General, United States Army  
The Adjutant General*

BERNARD W. ROGERS  
*General, United States Army  
Chief of Staff*

Published Under Authority of Commander, Naval Air Systems Command  
Published Under Authority of the Secretary of the Air Force.

**DISTRIBUTION**

To be distributed in accordance with DA Form 12-36A, organizational maintenance requirements for AN/APM-123.



CHANGE }  
No. 2 }

DEPARTMENTS OF THE ARMY, THE NAVY,  
AND THE AIR FORCE  
WASHINGTON, DC, 4 December 1975

**Operator and Organizational Maintenance Manual**  
**TEST SETS, TRANSPONDER**  
**AN/APM-123(V)1 (FSN 6625-948-0071)**  
**AN/APM-123(V)2 (FSN 6625-948-0077)**  
**AN/APM-123(V)3 (FSN 6625-948-0076)**

TM 11-6625-667-12/NAVAIR 16-30APM-123-1/TO 33A1-3-367-1, 4 June 1974, is changed as follows:

1. New or changed material is indicated by a vertical bar in the margin.
2. Remove and insert pages as indicated in the list below:

Remove pages  
i and 1-0  
None  
1-1 and 1-2  
2-9 and 2-10  
2-13 and 2-14

Insert pages  
i  
1 - 0  
1-1, 1-2 and 1-2.1  
2-9 and 2-10  
2-13 and 2-14

3. File this change sheet in front of the manual for reference purposes.

By Order of the Secretary of the Army:

FRED C. WEYAND  
*General, United States Army*  
*Chief of Staff*

Official:

PAUL T. SMITH  
*Major General, United States Army*  
*The Adjutant General*

Published Under Authority of the Secretaries of the Navy and the Air Force.

Distribution:

To be distributed in accordance with DA Form 12-36A, (qty rqr block No. 684) Organizational maintenance requirements for AN/APM-123.



Change }  
No. 1 }

DEPARTMENTS OF THE ARMY, THE NAVY,  
AND THE AIR FORCE  
Washington, DC, 3 December 1974

**Operator and Organizational Maintenance Manual**  
**TEST SETS, TRANSPONDER**  
**AN/APM-123(V)1 (FSN 6625-948-0071)**  
**AN/APM-123(V)2 (FSN 6625-948-0077)**  
**AN/APM-123(V)3 (FSN 6625-948-0076)**

TM 11-6625-667-12/NAVAIR 16-30APM-123-1/T0 33A1-3-367-1, 4 June 1974, is changed as follows:

1. Remove and insert pages as listed in the page list below.

<i>Remove</i>	<i>Insert</i>
2-13 and 2-14 . . . . .	.2-13 and 2-14

2. File this change sheet in the front of the manual for reference purposes.

By Order of the Secretary of the Army:

FRED C. WEYAND  
*General, United States Army*  
*Vice Chief of Staff*

Official:

VERNE L. BOWERS  
*Major General, United States Army*  
*The Adjutant General*

Published Under Authority of the Secretaries of the Navy and the Air Force.

DISTRIBUTION:

To redistributed in accordance with DA Form 12-36A, (qty rqr block no. 684) Organizational maintenance requirements for AN/APM-123.





**LIST OF EFFECTIVE PAGES**

Insert latest changed pages; dispose of superseded pages in accordance with applicable regulations,

**NOTE**

On a changed page, the portion of the text affected by the latest change is indicated by a vertical line, or other change symbol, in the outer margin of the page. Changes to illustrations are indicated by miniature pointing hands.

Total number of pages in this manual is 30 consisting of the following:

	<i>Page No.</i>		<i>Change No.</i>
Title/Table of Contents	-----		0
	<b>A</b>	-----	0
1-1	—	1-4 -----	0
2-1	—	2-14 -----	0
3-1	—	3-3 -----	0
App A	—	A1-1 -----	0
App B	—	B1-3 -----	0

---

#— Zero in this column indicates an original page



TECHNICAL MANUAL  
 No. 11-6625-667-12  
 NAVAIR 16-30APM-123-1  
 TECHNICAL ORDER  
 No. 33A1-3-367-1

DEPARTMENTS OF THE ARMY, THE NAVY,  
 AND THE AIR FORCE

WASHINGTON, DC, 4 June 1974

**Operator and Organizational Maintenance Manual**  
**TEST SET, TRANSPONDER AN/APM-123(V)1 (FSN 6625-948-0071),**  
**AN/APM-123(V)2 (FSN 6625-948-0077), AN/APM-123(V)3 (FSN 6625-948-0076)**

	Paragraph	Page
CHAPTER 1. INTRODUCTION		
Section 1. General		
Scope .....	1-1	1-1
Indexes of publications .....	1-2	1-1
Forms and records .....	1-3	1-1
Reporting of errors.....	1-3.1	1-1
Destruction of Army materiel to prevent enemy use. . . . .	1-3.2	1-1
Administrative storage .....	1-3.3	1-1
Reporting equipment improvement recommendations (EIR) . . . . .	1-3.4	1-1
II. Description and data		
Purpose and use .....	1-4	1-1
Technical characteristic .....	1-5	1-2.1
Differences in models .....	1-6	1-2.1
Items comprising an operable AN/APM-123(V) 1, 2, or 3 .....	1-7	1-2.1
Description of Test set, Transponder TS-1809/APM-123(V) .....	1-8	1-3
Description of minor components .....	1-9	1-3
CHAPTER 2. INSTALLATION AND OPERATING INSTRUCTIONS		
Section I. Service upon receipt of equipment		
Unpacking .....	2-1	2-1
Checking unpacked equipment .....	2-2	2-1
Installation of fuses, .....	2-3	2-1
Connections .....	2-4	2-4
II. Operation		
Operating controls and indicators .....	2-5	2-4
Types of operation .....	2-6	2-5
Preliminary test setup .....	2-7	2-5
Starting procedure .....	2-8	2-6
Transponder Set AN/APX-44 tests .....	2-9	2-9
Transponder Set AN/APX-68 and transponder Set AN/APX-72 tests .....	2-10	2-10
Stopping procedure .....	2-11	2-14
CHAPTER 3. MAINTENANCE INSTRUCTIONS		
Scope of maintenance .....	3-1	3-1
Tools and materials required for maintenance .....	3-2	3-1
Preventive maintenance .....	3-3	3-1
Preventive maintenance checks and service periods .....	3-4	3-1
Daily preventive maintenance checks and service chart .....	3-5	3-1
Monthly preventive maintenance checks and services chart .....	3-6	3-2
Quarterly preventive maintenance checks and services chart .....	3-7	3-2
Cleaning .....	3-8	3-2
Touchup painting instructions .....	3-9	3-3
General troubleshooting information .....	3-10	3-3
Troubleshooting chart .....	3-11	3-3
Replacement of lamps .....	3-12	3-3
Replacement effuses .....	3-13	3-3
APPENDIX A. REFERENCES .....		A1-1
B. MAINTENANCE ALLOCATION (Army only) .....		B1-1

\*This manual supersedes TM 11-6625-667-12, 14 April 1966, including all changes.

This Technical Manual and Equipment covered herein is configured for Inter-service use and maintainability by Direction of the Department of Defense AIMS System Program Office (DOD AIMS SPO). No changes shall be made to the equipment or Technical Manual without approval of the DOD AIMS SPO.

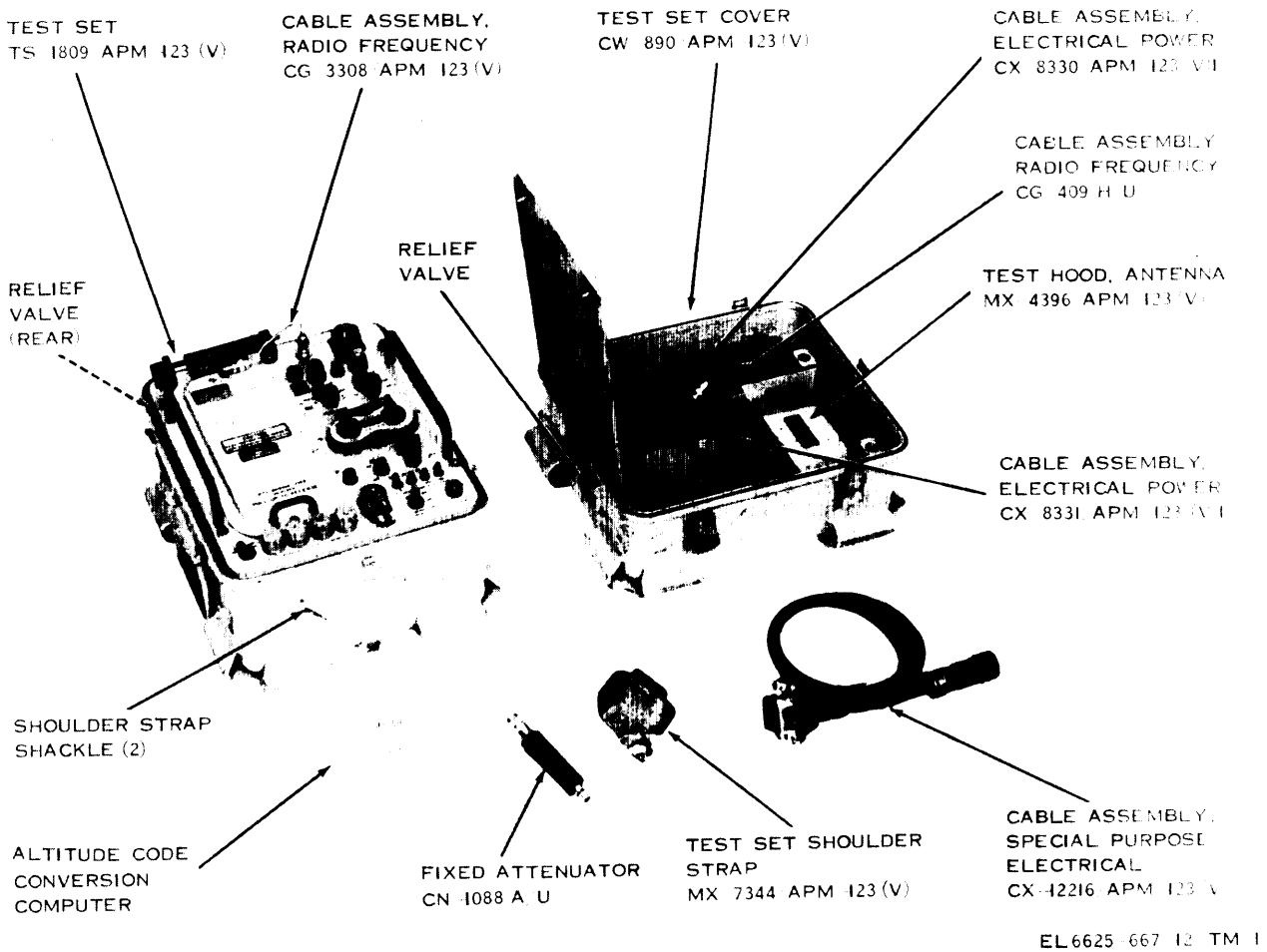

Figure 1-1. Test Set, Transponder AN/APM-123(V)1 (power cable for AN/APM-123(V)2 and 3 not shown).

# CHAPTER 1

## INTRODUCTION

### Section I. GENERAL

#### 1-1. Scope

*a.* This manual describes Test Sets, Transponder AN/PAM-123(V)1, 2 and 3 (test set) (fig. 1-1) and covers their operation and organizational maintenance. It includes instructions for operation, inspection and preventive maintenance of the test set. Also included in this manual is a maintenance allocation chart (App B.)

#### 1-2. Indexes of Publications

*a.* Refer to the latest issue of DA Pam 310-4 (Army), NAVSUP 2002 section viii (Navy), or T.O. 0-1-33 (Air Force) to determine whether there are new additions, changes, or additional publications pertaining to the equipment.

*b.* Refer to DA Pam 310-7 (Army) to determine whether there are modification work orders (MWO'S) pertaining to the equipment.

#### 1-3. Forms and Records

*a. Reports of Maintenance and Unsatisfactory Equipment.* Maintenance forms, records, and reports which are to be used by maintenance personnel at all maintenance levels are listed in and prescribed by TM 38-750 (Army). Air Force personnel will use AFM 66-1 for maintenance reporting and TO-00-35D54 for unsatisfactory equipment reporting. Navy personnel will report maintenance performed utilizing the Maintenance Data Collection Subsystem (MDSC) in accordance with OPNAVINST 4790-2, Vol 3 and unsatisfactory material/conditions (UR submissions) in accordance with OPNAVINST 4790.2, Vol 2, chapter 17.

*b. Report of Packaging and Handling Deficiencies.* Fill out and forward DD Form 6 (Packaging Improvement Report) as prescribed in AR 700-58/NAVSUPINST 4030.29/AFR 71-13/MCO P4030.29A, and DSAR 4145.8.

*c. Discrepancy in Shipment Report (DISREP) (SF 361).* Fill out and forward Discrepancy in Shipment Report (DISREP) (SF 361) as prescribed in AR 55-38/NAVSUPINST 4610.33A/AFR75-18/MCO

P4610.19B and DSAR 4500.15.

#### 1-3.1. Reporting of Errors

The reporting of errors, omissions, and recommendations for improving this manual by the individual user is encouraged. Reports should be submitted on DA Form 2028 (Recommended Changes to Publications and Blank Forms) or DA Form 2028-2 (Test) located in the back of the manual, and forwarded direct to Commander, US Army Electronics Command, ATTN: DRSEL-MA-Q, Fort Monmouth, NJ 07703. To use the form in the back of the manual, cut it out, fill it out as shown on the sample figure 1-2, fold it where shown, and drop it in the mail. A reply will be furnished direct to you.

#### 1-3.2. Destruction of Army Materiel to Prevent Enemy Use

Demolition of the test set will be accomplished only upon the order of the Commander. Refer to TM 750-244-2 for procedures to prevent the enemy from using or salvaging the test set.

#### 1-3.3. Administrative Storage.

For procedures, forms and records, and inspections required during administrative storage of this equipment, refer to TM 740-90-1.

#### 1-3.4. Reporting Equipment Improvement Recommendations (EIR)

*a. Army.* EIR's will be prepared using DA Form 2407 (Maintenance Request). Instructions for preparing EIR's are provided in TM 38-750, The Army Maintenance Management System. EIR's should be mailed directly to Commander, US Army Electronics Command, ATTN: DRSEL-MA-Q, Fort Monmouth, NJ 07703. A reply will be furnished directly to you.

*b. Air Force.* Air Force personnel are encouraged to submit EIR's in accordance with AFM 900-4.

*c. Navy.* Navy personnel are encouraged to submit EIR's through their local Beneficial Suggestion Program.

### Section II. DESCRIPTION AND DATA

#### 1-4. Purpose and Use

*a* Test Set, Transponder AN/APM-123(V) ( ) is a portable preflight test set for checking transponder sets such as Transponder Set AN/APX-44 and DOD AIMS AN/APX-64, and AN/APX-72, Transponder Sets. The test set provides coded radio-frequency (RF) interrogation signals to check the transponder set

receiver and decoder and, in addition, checks the transponder set transmitter and coder by evaluating the coded RF replies.

*b.* Any one of three types of RF coupling may be selected.

(1) Free-spacing radiation coupling by an adjustable front panel antenna.



# SOMETHING WRONG WITH THIS MANUAL?

THEN... JOT DOWN THE DOPE ABOUT IT ON THIS FORM, TEAR IT OUT, FOLD IT AND DROP IT IN THE MAIL!

FROM: (YOUR UNIT'S COMPLETE ADDRESS)  
 Commander  
 Stateside Army Depot  
 ATTN: AMSTA-US  
 Stateside, N.J. 07703

DATE 10 July 1975

PUBLICATION NUMBER TM 11-5840-340-12	DATE 23 Jan 74	TITLE Radar Set AN/SPS-76
---	-------------------	------------------------------

BE EXACT... PIN-POINT WHERE IT IS				IN THIS SPACE TELL WHAT IS WRONG AND WHAT SHOULD BE DONE ABOUT IT:
PAGE NO.	PARAGRAPH	FIGURE NO.	TABLE NO.	
2-25	2-28			<p>Recommend that the installation antenna alignment procedure be changed throughout to specify a 2° IFF antenna lag rather than 1°.</p> <p>REASON: Experience has shown that with only a 1° lag, the antenna servo system is too sensitive to wind gusting in excess of 25 knots, and has a tendency to rapidly accelerate and decelerate as it hunts, causing strain to the drive train. Hunting is minimized by adjusting the lag to 2° without degradation of operation.</p>
3-10	3-3		3-1	<p>Item 5, Function column. Change "2 db" to "3db."</p> <p>REASON: The adjustment procedure for the TRANS POWER FAULT indicator calls for a 3 db (500 watts) adjustment to light the TRANS POWER FAULT indicator.</p>
5-6	5-8			<p>Add new step f.1 to read, "Replace cover plate removed in step e.1, above."</p> <p>REASON: To replace the cover plate.</p>
		FO3		<p>Zone C 3. On J1-2, change "+24 VDC to "+5 VDC."</p> <p>REASON: This is the output line of the 5 VDC power supply. + 24 VDC is the input voltage.</p>

TYPED NAME, GRADE OR TITLE, AND TELEPHONE NUMBER  
 SSG I. M. DeSpirito 999-1776

SIGN HERE:  
*SSG I. M. DeSpirito*

DA FORM 1 AUG 74 2028-2 (TEST) P.S.--IF YOUR OUTFIT WANTS TO KNOW ABOUT YOUR MANUAL "FIND," MAKE A CARBON COPY OF THIS AND GIVE IT TO YOUR HEADQUARTERS.

HISA 1686-75

Figure 1-2. Sample DA Form 2028-2(TEST).

(2) Direct coupling to the transponder set by an RF cable and attenuator.

(3) Direct coupling of the test set to Antenna AT-884/APX-44 by an antenna test hood, a fixed attenuator, and an RF cable.

c. Modes 1,2, 3/A, C, TEST, or 4 can be selected, and codes 0000 to 7777 can be selected. The TEST mode is used in conjunction with the corresponding transponder set mode to allow testing when local identification transmissions may interfere with the use of the normal modes.

d. Emergency or identity operation checks can be selected and a three-pulse sidelobe suppression test can be selected in all modes, except 4.

e. A test set self-test can be performed, as a confidence level check, in all modes, except 4.

f. Mode 4 tests may be performed by direct coupling of the test set to an auxiliary interrogator computer or by direct coupling with an RF cable and attenuator.

**1-5. Technical Characteristics**

Transmitter

Frequency .....1,030 MHz ±0.02% crystal controlled.

Power output ..... — 6 dbm at antenna terminal.

Sidelobe suppression type ..... 3 pulse.

Pulse repetition frequency ..... 230 +5 - 10 pps

Pulse output group ..... 2 (P1 and P3) without sidelobe suppression or) (P1, P2, and P3) with sidelobe suppression.

Pulse spacing (P1 and P3):

Mode 1 ..... .3 usec ±0.2.

Mode 2 ..... .5usec ±0.2.

Mode 3/A ..... .8 usec ±0.2.

Mode C ..... .21 usec ±0.2.

TEST ..... 6.5 usec ±0.2.

4 ..... Modulation from external unit

Side lobe suppression pulse spacing (P1 and P2) ..... 2.0 usec ±0.15.

Receiver:

Frequency ..... 1.090 MHz ±0.5%(center).

Bandwidth (3 decibels down) ..... 6.5 MHz ±1.0.

Sensitivity ..... -9 dbm.

Gating ..... Only for duration of replies.

Decoding ..... Codes 0000 to 7777 including emergency and identity.

Power requirements:

Type ..... ac or dc

Ac ..... 115 volts ±10%, 50 through 420 Hz at 0.5 ampere.

Dc ..... .28 ±3 volts at 1.5 ampere.

**1-6. Differences in Models**

Official nomenclature, AN/APM-123(V), followed by the number 1, 2, or 3 identifies the type of power cables supplied with the AN/APM-123(V) for use by the Army, Navy, or Air Force. Number 1 designates that the components of the test set include power cables that can only be used by the Army. Number 2 designates that the components of the test set include power cables that can only be used by the Navy. Number 3 designates that the components of the test set include power cables that can only be used by the Air Force. Power cable connections for the AN/APM-123(V)1, AN/APM-123(V)2, and AN/APM-123(V)3 are given in paragraph 2-4. Except for the difference in power cables and test hood, the components of the AN/APM-123(V)1, AN/APM-123(V)2, and AN/APM-123(V)3 are mechanically and electrically identical.

**1-7. Items Comprising an Operable AN/APM-123(V)1, 2, or 3**

QTY	ITEM	AN/APM-123(V)( )			DIMENSIONS (in)			UNIT WEIGHT
		Army	Navy	AF	Height	Length	Width	(lbs)
		(1)	(2)	(3)				
	Test Set, Transponder AN/APM-123(V) ( )				12½	15½	13¼	50
1	Consisting of: Test Set, Transponder TS-1809/APM-123(V)	X	X	X	4-13/16	15½	13¼	23.5
1	Cable Assembly, Electrical Power	X					8 ft	1.5
1	Cable Assembly, Electrical Power CX-8331/APM-123(V) 1	X					50 ft	3





QTY	ITEM	AN/APM-123(V) ( )			DIMENSIONS (in)			UNIT weight
		Army	Navy	AF	Height	Length	Width	(lbs)
		(1)	(2)	(3)				
1	Test Set Cover CW-890/APM-123(V)	X	X	X				8 3/4
1	Cable Assembly, Radio Frequency CG-3308/APM-123(V)	X	X	X		6		1/2
1	Cable Assembly, Radio Frequency CG-409H/U	X	X	X		25 ft		1/2
1	Test Hood, Antenna MX-4396/APM-123(V)	X	X		3 3/4	7 1/2	2 5/8	1/2
1	Fixed Attenuator CN-1088A/U	X	X	X				1/2
1	Test Set Shoulder Strap MX-7344/APM-123(V)	X	X	X				1/2
1	Adapter, Connector UG-564/U	X	X	X				1/2
1	TM 11-6625-667-12/TO 33A-3-367-1/NAVAIR 16-30APM-123-1	X	X	X				
1	Cable Assembly, Electrical Power CX-11626/APM-123(V)		X	X				
1	Cable Assembly, Electrical Power CX-11627/APM-123(V)		X	X				
1	Cable Assembly, Electrical Power 11628/APM-123(V)2		X					
1	Cable Assembly, Electrical Power CX-11629/APM-123(V)3			X				
1	Cable Assembly, Special Purpose Electrical CX-12216/APM-123(V) (stored externally to case)	X	X	X				
1	Altitude Code Conversion Computer	X	X	X				

*b. Running Spares*

Quantity	Item
2	Fuse, 1-amp, 115 volts (F02A230V1A)
2	Fuse 2-amp, 28 volts (F02A2502A)

**1-8. Description of Test Set, Transponder TS-1809/APM-123(V)**

The test set operates from either 115 volts alternating current (ac) or 28 volts direct current (dc) and simulates the operation of an interrogator. Interrogation is at 1,030 megahertz (MHz) and receiving at 1,090 MHz. The test set covers modes 1, 2, 3/A, C, TEST, and 4 and codes 0000 through 7777. ACCEPT and REJECT indicators are on the front panel (fig. 2-2). All operating controls, connectors, and antenna are on the front panel. Except for one special purpose cable, CX-12216/APM-123 (V), minor components are stored in Test Set Cover CW-890/APM-123(V).

1-9. Description of Minor Components

Description of the test set minor components is given in *a* through *j* below.

*a.* Fixed Attenuator CN-1088A/U provides 55

decibels (db) ±1 attenuation (25 watts) and 50 ohms input and output impedance. Fixed Attenuator CN-1088A/U is connected between the test set and transponder set with Cable Assembly, Radio Frequency CG-409H/U for direct coupling tests.

*b.* Cable Assembly, Electrical Power CX-8330/APM-123(V)1 is fitted with a plug-type 3 pin connector on one end and a 5-pin connector on the other end. The power cable assembly connects the AN/APM-123(V)1 to a 115-volt, 50-through 420-Hertz, ac power source.

*c.* Cable Assembly, Electrical Power CX-8331/APM-123(V)1 is fitted on one end with a 5-pin connector and two alligator clips on the other end. The power cable assembly connects the AN/APM-123(V)1 to a 28-volt dc power source.

*d.* Cable Assembly, Electrical Power CX-11626/APM-123(V) is fitted on one end with a 5-pin connector and a 3-pin connector on the other end. The power cable assembly connects the AN/APM-123(V)2 or AN/APM-123(V)3 to a 115-volt, 60 Hertz ac power source.

*e.* Cable Assembly, Electrical Power CX-11627/APM-123(V) is fitted on one end with a 5-pin connector and a 2-pin connector on the other end. The power cable assembly connects the AN/APM-123(V)2 or AN/APM-123(V)3 to a 28-volt dc power source.

*f.* Cable Assembly, Electrical Power CX-11628/APM-123(V)2 is fitted on one end with a 4-pin connector and a 3-pin connector on the other end. The power cable assembly adapts Cable Assembly, Electrical Power CX-11626/APM-123(V) to a 115-volt, 400-Hertz source for the AN/APM-123(V)2.

*g.* Cable Assembly, Electrical Power CX-11629/APM-123(V)3 is fitted on one end with a 9-pin connector and a 3-pin connector on the other end. The power cable assembly adapts Cable Assembly, Electrical Power CX-11626/APM-123(V) to a 115-volt 400-Hertz source for the AN/APM-123(V)3.

*h.* Cable Assembly, Radio Frequency CG-409H/U is used for direct coupling type tests. One end is connected to the test set and the

other end to Fixed Attenuator CN-1088A/U (a above).

*i.* Test Hood, Antenna MX 4396/APM-123(V) together with Fixed Attenuator CN-1088A/U and Cable Assembly, Radio Frequency CG409H/U is used to couple the test set to AT-884/APX-44 type antennas.

*j.* Adapter, Connector UG-564U is used to adapt Fixed Attenuator CN-1088A/U to the antenna jack of Transponder Set AN/APX-72 when direct coupling tests are performed.

*k.* Cable Assembly, Special Purpose Electrical CX-12216/APM-123(V) is used to connect the test set to mode 4 equipment when performing mode 4 tests. When not in use the cable is stored external to the test set.

*l.* Cable Assembly, Radio Frequency CG3308/APM-123(V) is used to connect the test set PROBE connector to the test antenna when indirect coupling tests are performed.

*m.* Test Set Shoulder Strap MX-7344/APM-123 (V) is hooked to shackles on both ends of the test set and used to support the test set when being carried.

## CHAPTER 2

### INSTALLATION AND OPERATING INSTRUCTIONS

---

#### Section I. SERVICE UPON RECEIPT OF EQUIPMENT

#### 2-1. Unpacking

*a. Packaging Data.* When packed for shipment, the test set is placed in a corrugated carton. A typical shipping carton and its contents are shown in figure 2-1. The corrugated carton is 13 1/2 inches high, 22 1/2 inches deep, and 24 inches wide; the volume is 6.7 cubic feet. The gross weight of the carton and its contents is approximately 55 pounds.

*b. Removing Contents*

(1) Place the outer container in a location that provides vertical clearance of at least twice the container height. Keep the container in an upright position, and open the top of the container.

(2) Remove the contents from the outer container, and then remove the inner container from the screen foil bag. Open the inner container.

(3) Remove the top layer cushioning and all side layers of cushioning from the inner container.

(4) Lift the test set from the inner container and remove the paper wrapping.

#### 2-2. Checking Unpacked Equipment

*a.* Inspect the equipment for damage incurred during shipment. If the equipment has been damaged, refer to paragraph 1-3b for instructions.

*b.* See that the equipment is complete as listed on the packing slip. If a packing slip is not available, check the equipment against the list of components in paragraph 1-7. Report all discrepancies in accordance with paragraph 3-1c. Shortage of a minor assembly or part that does not affect proper functioning of the equipment should not prevent use of the equipment.

*c.* If the equipment has been used or reconditioned, see whether it has been changed by a modification work order (MWO). If the equipment has been modified, the MWO number will appear on the front panel near the nomenclature plate. If modified, see that any operational instruction changes resulting from the modification have been entered in the equipment manual.

NOTE

Current MWO'S applicable to the equipment are listed in DA Pam 310-7.

#### 2-3. installation of Fuses

(fig. 2-2)

The test set is shipped with fuses installed. Be sure the proper fuses are inserted in the fuse holders on the front panel of the test set. The following chart shows the location and ratings of the fuses:

Fuses			
Reference Symbol	Amps	Volts	Circuit
A1F1 and A1F3	1	115	Ac input
A1F2 and A1F4	2	28	Dc input

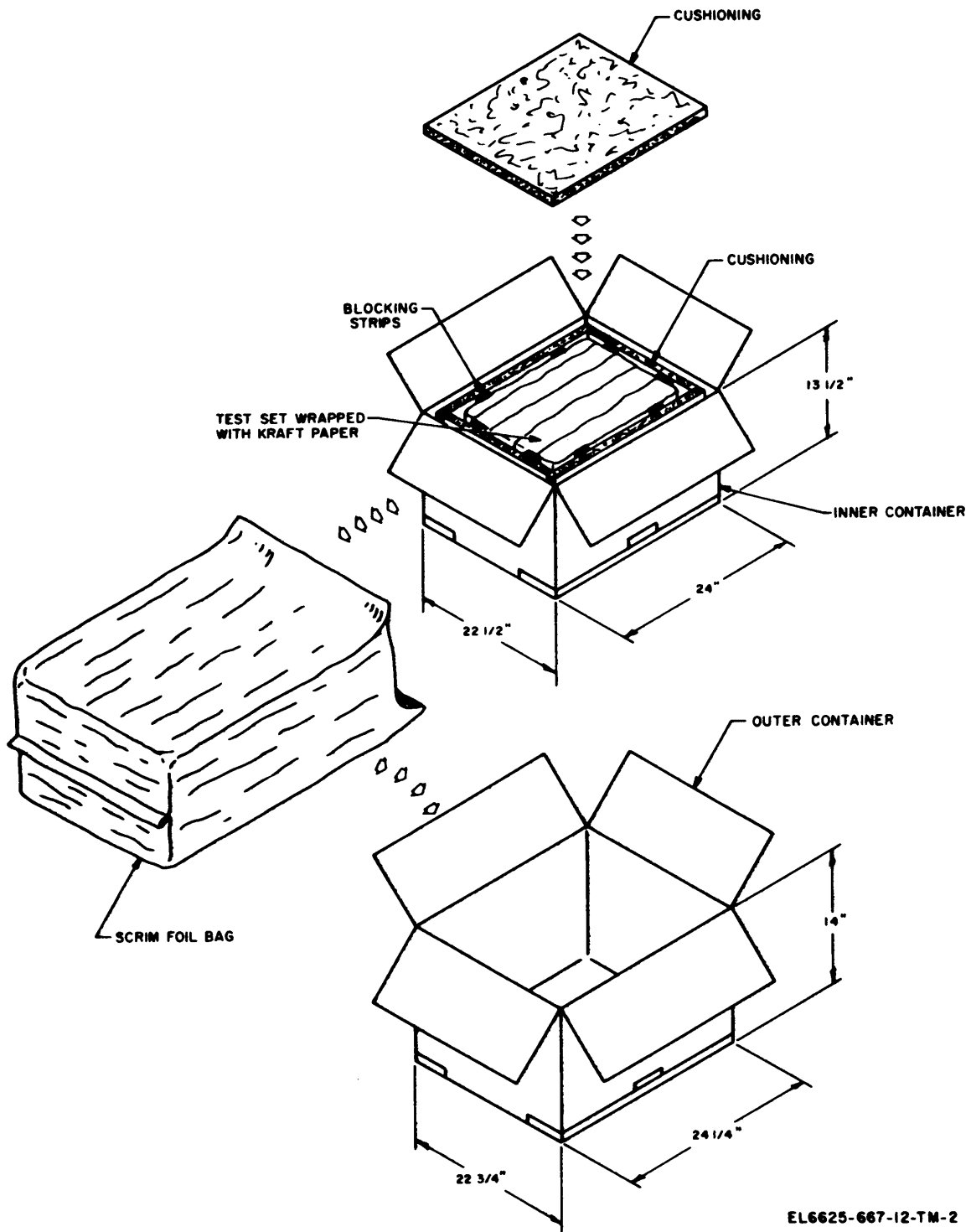

EL6625-667-12-TM-2

Figure 2-1. Typical packaging.

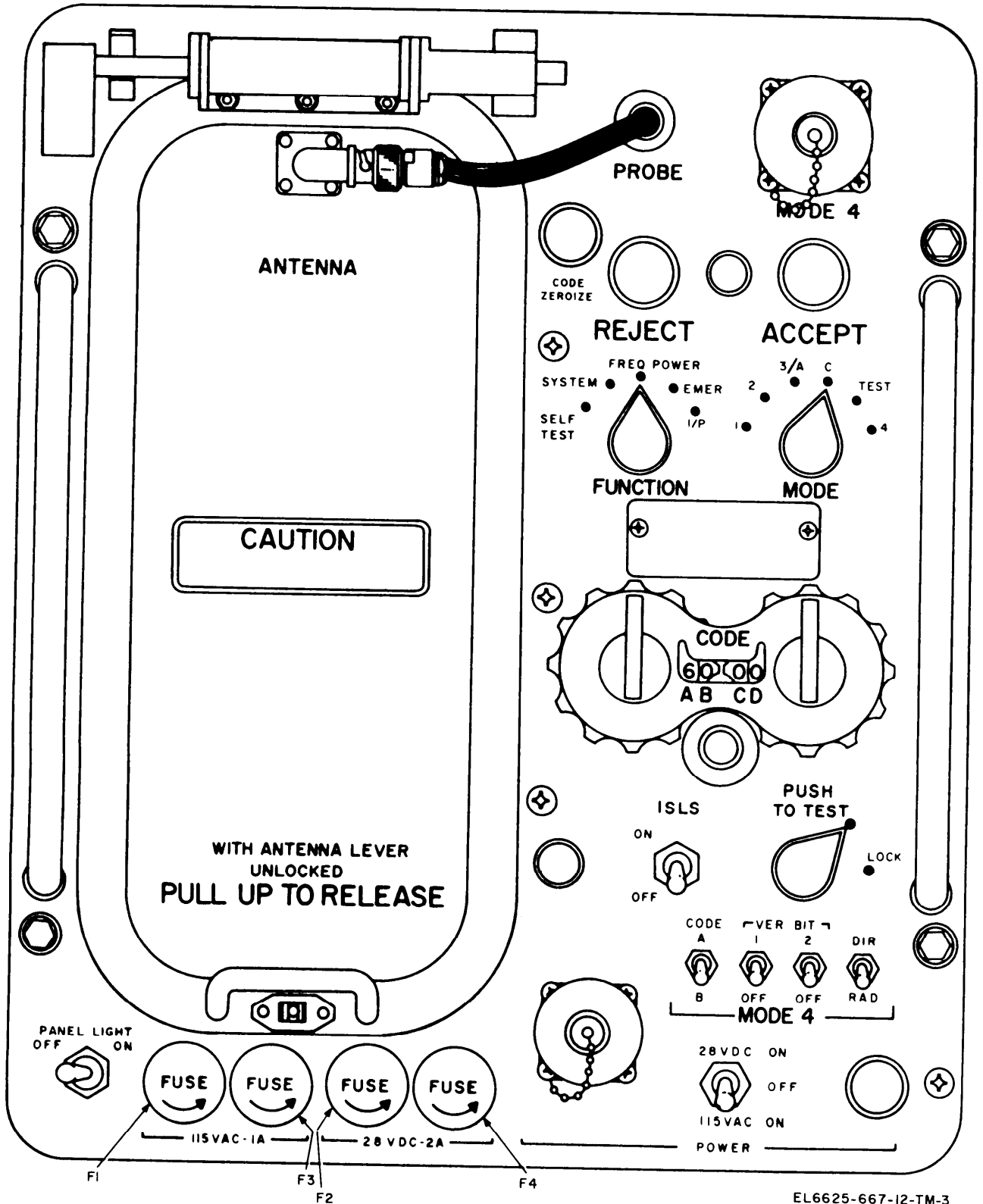

EL6625-667-12-TM-3

Figure 2-2. Test set controls and indicators.

## 2-4. Connections

The following chart lists the power cables by nomenclature and shows point of origin and destination for connection between the test set and power source. Use applicable cable for connection to either an ac or dc power source.

Test Set	Cable	Connects		
		From test set	Through	To
AN/APM-123(V)1 (Army)	CX-8330/APM-123(V)1	POWER connector		Ac power source, 50 through 400 Hz. Dc power source.
	CX-8331/APM-123 (V)1	POWER connector		
AN/APM-123(V)2 (Navy)	CX-11627/APM-123(V)	POWER connector		Dc power source. Ac power source, 60 Hz. Ac power source, 400 Hz. Test Set Power connector
	CX-11626/APM-123(V)	POWER connector		
	CX-11626/APM-123(V)	POWER connector	CX-11628/APM-123(V)2	
	CX-11628/APM-123(V)2	POWER source	CX-11626/APM-123(V)	
AN/APM-123(V)3 (Air Force)	CX-11627/APM-123(V)	POWER connector		Dc power source. Ac power source, 400 Hz. Ac power source, 60 Hz. Test Set Power connector
	CX-11626/APM-123(V)	POWER connector	CX-11629/APM-123(V)3	
	CX-11626/APM-123(V)	POWER connector		
	CX-11629/APM-123(V)3	POWER source	CX-11626/APM-123(V)	

## Section II. OPERATION

### 2-5. Operating Controls and Indicators

Control or Indicator	Function	
28VDC-115VAC-ON-OFF power switch	Connects input for 115 volts ac or 28 volts dc operation or turns off the test set.	
	Sw Pos	Action
	OFF 115 VAC  28 VDC	Turns off the test set. Selects 115 volts ac input and turns the test set on.  Selects 28 volts dc input and turns the test set on.
POWER indicator	Lights (RED) when the test set is on.	
PUSH TO TEST switch	Starts the test when pressed and stops test when released. The LOCK position locks the PUSH TO TEST switch in the depressed position.	
ISLS switch	[n the OFF position, turns off sidelobe suppression. In the ON position, turns on sidelobe suppression test.	
CODE AB-CD controls	Select any of the 4,096 codes (0000 through 7777) for reply decoding. CODE AB controls select the first two digits from 00 through 77. CODE CD controls select the last two digits from 00 through 77.	
CODE ZEROIZE alarm indicator	Lights to indicate a malfunction in the interrogation system of mode 4 equipment under test.	
FUNCTION switch	Sw Pos	Action
	SELF TEST SYSTEM	Permits test set confidence level check. Enables evaluation of overall transponder set operation, including coder.
	FREQ-POWER	Permits evaluation of overall transponder set operation, excluding the coder. Primarily used after a system reject indication to establish whether the coder caused the failure.

Control or Indicator	Function	
	Sw Pos	Action
MODE switch	EMER	Permits checking all transponder set emergency operations including civil emergency operation check for code 7600 and 7700.
	I/P	Enables evaluation of transponder set indentity operation (military or civil).
ACCEPT indicator REJECT indicator PANEL LIGHT ON-OFF SWITCH		
	Sw Pos	Mode
	1	1 (military).
	2	2 (military).
	3/A	3/A (military and civil).
	C	C (military and civil).
TEST	Test.	
4	4 (military).	
MODE 4 switches: CODE VER BIT DIR-RAD	A and B	Provides computer under test with code information selected by the operator.
	1 and 2 OFF DIR RAD	Controls verify bits of computer under test. Selects mode 4 direct connection. Selects radiation test accept conditions.

**2-6. Types of Operation**

a. The test set may be operated to perform radiation or nonradiation tests. The difference between the operations for the radiation and nonradiation tests is the means of coupling RF energy between the test set and transponder set. Free-spacing coupling for radiation tests is performed using an adjustable antenna mounted on the front panel of the test set. Nonradiation tests are performed either by direct cable-attenuator coupling to the transponder set or by an antenna test hood for the AT-884/APX-44 type antennas.

b. For any type of operation, perform the following procedures:

- (1) Preliminary test setup (para 2-7).
- (2) Starting procedure (para 2-8).
- (3) Test procedures for Transponder Set being tested (AN/APX-44, AN/APX-68, AN/APX-72).
- (4) Stopping procedure (para 2-11).

**2-7. Preliminary Test Setup**

The following procedures describe the preliminary test setup for radiation and nonradiation operation. Before preceding, unscrew the relief valves counterclockwise (fig. 1-1) two turns to release any internal pressure.

**WARNING**

Pressure must be released before the cover is removed or cover may spring up forcibly and cause serious injury.

a. *Radiation Operation* The test set must be correctly positioned with respect to distance and angle from the transponder set antenna for proper test results. Normally, the distance should be approximately 50 feet within line-of-sight of the transponder set antenna. The front panel antenna must be posi-

tioned for horizontal polarization ((4) below) or vertical polarization ((5) below) depending on the position of the aircraft transponder set antenna. The line-of-sight path between the test set and transponder set antenna must be free of obstructions. This includes parts of the aircraft to which the transponder set antenna is attached and nearby objects. Obstructions between the test set and aircraft transponder set antenna will cause an abnormal loss of transmitted RF power and result in an incorrect reject indication. In addition, nearby objects may cause RF losses by reflecting a portion of the radiated signal so that cancellations occur. Transponder set antenna flush-mounted on top of aircraft may require that the test set be raised above ground level. Proceed as follows:

- (1) Place the test 50 feet ±10 from the aircraft transponder set antenna so that obstructions are avoided between the test set and aircraft transponder set antenna.
- (2) Remove the test set cover by releasing its latches.
- (3) Position the test set so that the control panel faces up.

(4) Some aircraft transponder set antennas may be located on wheel flaps, or other movable objects, which horizontally position the normally vertical polarized aircraft transponder set antenna. For horizontally polarized aircraft transponder set antennas, the test set antenna must also be positioned for horizontal polarization. To position the test set antenna for horizontal polarization, grasp the antenna handle (fig. 2-3) and gently pull up the antenna to disengage it from a snap latch. Pull the antenna up at the right-

hand corner to unlock it from the vertical detent locking pin. Lift the antenna up until a horizontal detent locking pin locks the antenna. Direct the arrow on the antenna toward the aircraft transponder set antenna.

(5) To position the antenna for vertical polarization, grasp the antenna handle (fig. 2-3) and gently pull up the antenna to disengage it from a snap latch. Direct the arrow on the antenna toward the aircraft transponder set antenna. Adjust the vertical angle of the antenna until it is directed at the aircraft antenna.

*b. Nonradiation Operation (Direct Coupling).* The test set is connected through Fixed Attenuator CN-1088A/U directly or indirectly, to the equipment under test. Proceed as follows:

**WARNING**

When a 115-volt ac 400 Hertz power source is to be used and the transponder to be tested is installed in an aircraft, connect test set to transponder before connecting test set power cable.

(1) Place the test set near the transponder set antenna input connector.

(2) Release the test set cover latches and remove the cover, Remove the CG-409H/U RF cable and attenuator (fig. 1-1) from the cover.

(3) Disconnect the antenna RF cable from the PROBE jack (fig. 2-2) and connect the RF cable, removed from the cover, to the PROBE jack. Connect one end of the CN-1088A/U attenuator to the RF cable and the other end of the attenuator to the selected transponder set antenna test input.

**NOTE**

When testing the AN/APX-72, connect the UG-564/U connector adapter between the AN/APX-72 antenna input and the attenuator.

*c. Nonradiation Operation (Antenna Test Hood Coupling).*

**NOTE**

The antenna test hood is used only for AT-884/APX-44 type antennas.

(1) Release the test set cover latches and remove the cover.

(2) Remove the CG-409H/U RF cable, CN-1088A/U attenuator, and antenna test hood from the cover and connect the equipment as illustrated in figure 2-4.

(3) Snap the test hood in position over the AT-884/APX-44 antenna so that the arrow on the bottom of the test hood points toward the forward end of the aircraft. Use the antenna flanges mounted on the aircraft (fig. 2-4).

(4) Disconnect the cable from the PROBE connector and connect the free end of the CG-409H/U RF cable to the PROBE connector.

**2-8. Starting Procedure**

Set up the equipment as instructed in paragraph 2-7 and proceed as follows to start the equipment:

*a.* Set the test set controls as follows:

Control	Position
28 VDC-115VAC-ON-OFF power switch	OFF.
MODE switch . . . . .	Any mode, except mode 4.
ISLS switch . . . . .	OFF.
FUNCTION switch . . . . .	SELF TEST.
AB-CD CODE controls . . . . .	0000.
VER BIT 1 . . . . .	OFF.
VER BIT 2 . . . . .	OFF.

*b.* Remove the power cable from the cover.

*c.* Connect the power cable between the power source and test set POWER connector (para 2-4).

**CAUTION**

When connecting dc power cables supplied with battery clips to a dc power source, be sure the battery clip with a red insulator is connected to the positive (+) battery terminal. Improper connection will damage the equipment.



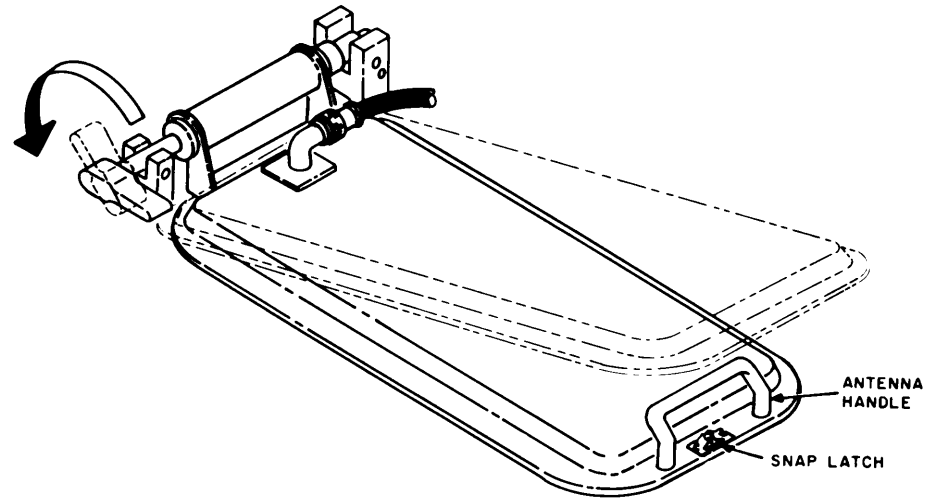

A. VERTICAL ANTENNA POLARIZATION.

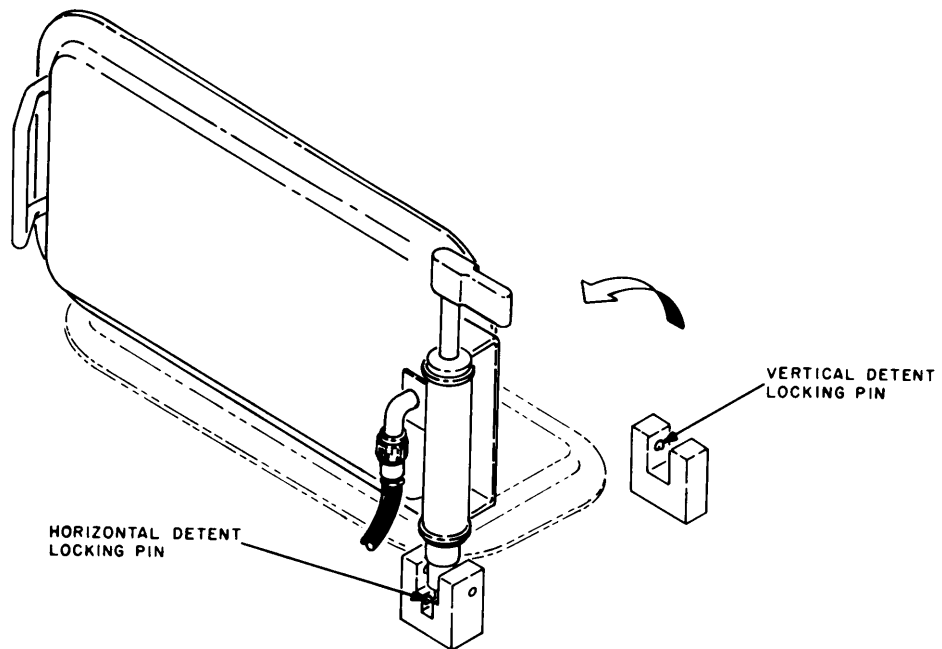

B. HORIZONTAL ANTENNA POLARIZATION.

EL6625-667-12-TM-4

Figure 2-3. Antenna positioning for vertical and horizontal polarization

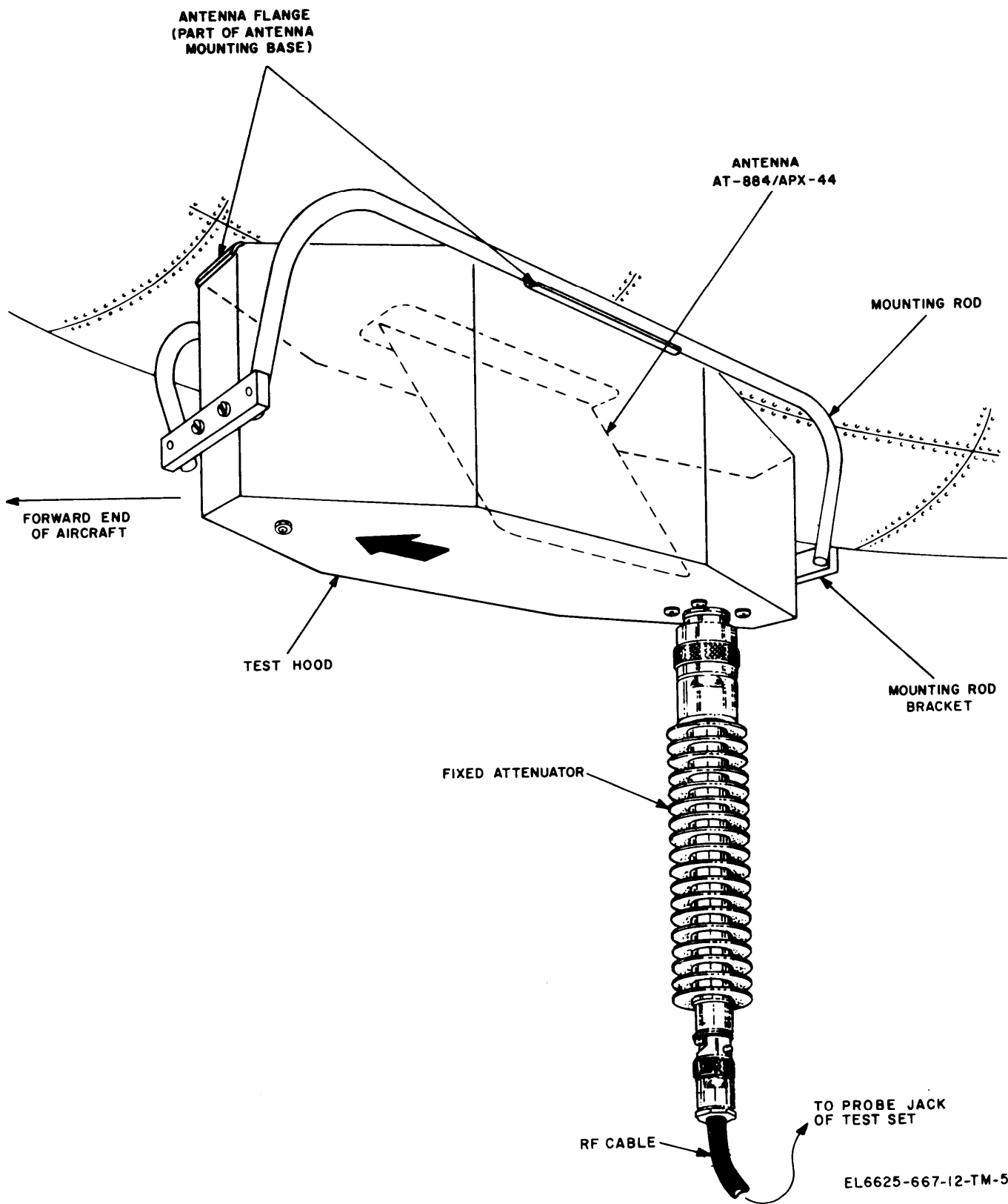

Figure 2-4. Test hood installation.

d. Set the 28 VDC-115 VAC-OFF power switch to 115 VAC if an ac power source is used or to 28 VDC if a dc power source is used. The POWER indicator should light. Allow the test set to warmup for approximately 2 minutes.

e. Press the PUSH TO TEST switch and rotate to LOCK position. The ACCEPT indicator should light. If the REJECT indicator lights, the test set requires higher level maintenance.

Set the ISLS switch to ON. The ACCEPT indicator should remain lighted.

g. Set the ISLS switch to OFF.

h Release the PUSH TO TEST switch by moving from LOCK position. The ACCEPT indicator should go out.

i Turn FUNCTION switch to SYSTEM and MODE switch to 4.

j. Briefly depress the PUSH TO TEST switch. The REJECT indicator should light. If the ACCEPT indicator lights, the test set requires a higher level maintenance.

**2-9. Transponder Set AN/APX-44 Tests**

The operating control positions (code mode, etc) of the test set must agree with the operating control positions of the transponder set under test. Perform the preliminary test setup for radiation operation (para 2-7a) starting procedure (para 2-8), and proceed as follows:

Mode	Maximum Code Range	Test Set CODE AB-CD Control Setting	AN/APM-44	
			Control	Setting
1	00-73	0000-7300 (CD always 00)	MODE 1	00-73
2	0000-7777	Selected four digit code number (0000-7777).	Receiver-transmitter mode 2 toggle switches.	Four digit code number
3	00-77	0000-7700	MODE 3	00-77

(3) Press the test set PRESS TO TEST switch. The ACCEPT indicator should light. If the REJECT indicator lights, the coder operation is abnormal; perform the procedure given in (4) below and then perform the procedures given in (5) and (6) below as applicable.

(4) Press and turn the test set PRESS TO TEST switch to LOCK, and set the test set FUNCTION switch to FREQ-POWER. If the ACCEPT indicator lights, the transponder power output is normal and the coder operation abnormal. If the REJECT indicator lights, perform the procedures given in (5) and (6) below to determine whether the aircraft transponder,

a. *Preliminary Panel Control Settings.* Set the transponder set receiver-transmitter MODE 2 toggle switches to OFF. Set the controls of Transponder Set Control C-2714/APX-44 as outlined in the chart below.

Control	Position
Master control	NORM.
Function control	MOD.
I/P switch	OFF.
MODE 2 0N-OFF switch	OFF.
MODE 3 0N-OFF switch	OFF.
MODE 1 code control	00.
MODE 3 code control	00.

b. *Systems Tests.* Set the test set FUNCTION switch to SYSTEM and proceed as follows:

(1) Use the chart below to set the mode controls of the test set and C-2714/APX-44 for the desired mode.

Mode	Test Set MODE control Position	C-2714/APX-44	
		Control	Setting
2	2	MODE 2	ON
		MODE 3	OFF
3	3/A	MODE 3	ON
		MODE 2	OFF

(2) The maximum code range for a particular Transponder Set AN/APX-44 mode is shown in the chart below. The transponder set mode 2 code toggle switches are located behind the receiver-transmitter front panel cover. All other code controls are on the C-2714/APX-44. Use the chart below to set the code controls of the test set and transponder set for the desired code.

coder, or antenna is abnormal.

(5) Move the test set 10 feet closer to the aircraft transponder set antenna. Set the FUNCTION switch to SYSTEM. If the ACCEPT indicator lights, the transponder set power output is abnormal. If the REJECT indicator lights, the coder operation is abnormal or the antenna system is defective. To determine the defective component, perform the procedure in (6) below.

**CAUTION**

The test set must not be closer than 20 feet from the aircraft transponder set antenna

because the test will not be valid if it is too close. In addition, damage to the detector diode in the aircraft transponder set receiver may result.

(6) Connect the test set to the aircraft transponder set for nonradiation operation (direct coupling) (para 2-7b). Press the test set PUSH TO TEST switch. If the ACCEPT indicator lights, the transponder set antenna system is defective. If the REJECT indicator lights, the transponder set is defective.

(7) Set the test set ISLS switch to ON. The REJECT indicator should light.

(8) Set the test set ISLS switch to OFF.

*c. Emergency Tests (Military and Civil).*

(1) Military emergency tests can be performed in modes 1, 2, and 3A. Civil emergency tests can be performed in mode 3/A only. Set the C-2714/APX-44 (control unit) function switch to EMER and use the chart below to set the mode and code controls of the test set and transponder set.

**NOTE**

Emergency operation may interfere with distress signals. Do not radiate Code 7700. Perform the tests as quickly as possible.

Mode	AN/APX-44			Test set controls		
	Function	Mode	Mode/code setting	Function	Mode	Code
1	MOD or CIVIL	ALL OFF	1/00	EMERGENCY	1	0000
2	MOD or CIVIL	MODE 2 control to ON	All receiver-transmitter mode 2 toggle switches to OFF	EMERGENCY	2	0000
3	MOD or CIVIL	MODE 2 control to OFF MODE 3 control to ON	3/00	EMERGENCY	3/A	0000

(2) Press the PUSH TO TEST switch. The ACCEPT indicator should light.

(3) Set the C-2714/APX-44 master control to NORM.

*d. Identity Test.*

(1) Set the C-2714/APX-44 (control unit) I/P switch to I/P and use the chart below to set the controls of the test set and transponder set for the desired code.

Mode	AN/APX-44			Test set controls		
	Function	Mode	Mode/code setting	Function	Mode	Code
1	MOD	All controls to OFF	1/00	I/P	1	0000
2	MOD or CIVIL	MODE 2 control to ON	All receiver-transmitter mode 2 toggle switches to OFF.	SYSTEM	2	0000
3	MODE or CIVIL	MODE 2 control to OFF MODE 3 control to ON	3/00	EMERGENCY	3/A	0000

(2) Press the PUSH TO TEST switch. The ACCEPT indicator should light for 30 seconds +20—15.

(3) Set the C-2714/APX-44 master control to OFF.

**2-10. Transponder Sets AN/APX-68 and AN/APX-72 Tests**

The operating control positions (code, mode, etc.) of the test set must agree with the operating control positions of the transponder set under test. Perform the preliminary test setup for radiation operation (para 2-7a), starting procedure (para 2-8), and proceed as follows:

*a. Preliminary Panel Control Settings.* The transponder set receiver-transmitter coder selector switches for mode 2 code are preset to a four-digit code. Set Transponder Control C-6280A(P)/APX controls as outlined in the chart below.

Control	Position
MASTER Switch	STBY for 1 minute then set to NORM.
IDENT-MIC switch	OUT
M-1 TEST switch	OUT
M-2 TEST switch	OUT
M-3/A TEST switch	OUT
M-C switch	OUT
MODE 4 switch	OUT
MODE 1 code control	.00
MODE 3/A code control	.0000

b. *Systems Test.* Set the test set FUNCTION switch to SYSTEM and proceed as follows:

(1) Use the chart below to set the mode controls of the test set and C-6280A(P)/APX for the desired mode.

MODE	Test set MODE control position	C-6280A(P)/APX	
		Control	Setting
1	1	M-1 M-2, M-3/A, M-C MODE 4	ON OUT OUT

MODE	Test set MODE control position	C-6280A(P)/APX	
		Control	Setting
2	2	M-2 M-1, M-3, M-C MODE 4	ON OUT OUT
3/A	3/A	M-3 M-1, M-3, M-C MODE 4	ON OUT OUT

(2) Use the chart below to set the code controls of the test set and transponder set for the desired code.

MODE	Test set CODE controls A,B,C,D setting	C-6280A(P)/APX	
		Control	Setting
1	0000-7300 (CD always 00)	MODE 1	00-73
2	Selected four digit code number (0000-7777)	Receiver transmitter mode 2 toggle switches.	Four digit code number
3/A	0000-7777	MODE 3/A	0000-7777

(3) Perform the procedures outlined in paragraph 2-9b(3).

c. *Emergency Tests (Military and Civil).*

(1) Military emergency tests can be performed in modes 1, 2, and 3/A. Civil emergency tests can be performed in mode 3/A only. Set the C-6280A (P)/APX MASTER switch to EMER

and the test set FUNCTION switch to EMER. Use the chart below to set the mode and code controls of the test set and transponder set.

**NOTE**

Emergency operation may interfere with distress signals. Perform the tests as quickly as possible.

Mode	Test set controls		Transponder Controls		
	MODE	CODE	C-6280A(P)/APX	RT-859/APX-72	Setting
1	1	0000-7300 (CD always 00).	M-1 to ON and all others to OUT.	MODE 2 code	00-73
2	2	Same as preset for digits on transponder.	M-2 to ON and all others to OUT.		Preset between 0000-7777.
3/A	3/A	7700 (for normal use) 7600 (for communication failure).	M-3 to ON and all others to OUT.		Preset

(2) Press the test set PUSH TO TEST switch. The ACCEPT indicator should light.

(3) Set the C-6280A(P)/APX master switch to NORM.

d. *Identity Test.*

(1) Set the C-6280A(P)/APX IDENT switch to IDENT.

(2) Set the test set and C-6280A(P)/APX code and mode controls in accordance with the instructions outlined in b(1) and (2) above.

(3) Set the test set FUNCTION switch to I/P and press the test set PUSH TO TEST switch. The ACCEPT indicator should light for approximately 25 seconds.

e. *Mode C (Altitude) Tests.* Mode C tests are performed with the transponder connected to an auxiliary altitude digitizer or altitude encoder.

(1) Set the test set MODE switch to C and FUNCTION switch to SYSTEM.

(2) Set the C-6280A(P)/APX MC switch to ON and all other mode switches to OUT.

(3) If encoder altimeter is used, adjust BARO set control on face of altimeter until the BARO display on face of altimeter indicates 29.92.

(4) Obtain the local barometric altitude from the operations group and refer to the Altitude Code Conversion Computer provided or the

chart below for the test set CODE control settings.

**NOTE**

The chart provides altitudes in increments of 100-foot values. The code settings shown for each value should be used for altitudes 50 feet below and above that shown. For example, when the local barometric altitude is between 50 and 150 feet, use 100 feet, etc.

Altitude	Reply code			
	A	B	C	D
-1,000	0	0	2	0
-900	0	0	3	0
-800	0	0	1	0
-700	0	4	1	0
-600	0	4	3	0
-500	0	4	2	0
-400	0	4	6	0
-300	0	4	4	0
-200	0	6	4	0
-100	0	6	6	0
000	0	6	2	0
100	0	6	3	0
200	0	6	1	0
300	0	2	1	0
400	0	2	3	0
500	0	2	2	0
600	0	2	6	0
700	0	2	4	0
800	0	3	4	0
900	0	3	6	0
1,000	0	3	2	0
1,100	0	3	3	0
1,200	0	3	1	0
1,300	0	7	1	0
1,400	0	7	3	0
1,500	0	7	2	0
1,600	0	7	6	0
1,700	0	7	4	0
1,800	0	5	4	0
1,900	0	5	6	0
2,000	0	5	2	0
2,100	0	5	3	0
2,200	0	5	1	0
2,300	0	1	1	0
2,400	0	1	3	0
2,500	0	1	2	0
2,600	0	1	6	0
2,700	0	1	4	0
2,800	4	1	4	0
2,900	4	1	6	0
3,000	4	1	2	0
3,100	4	1	3	0
3,200	4	1	1	0
3,300	4	5	1	0
3,400	4	5	3	0
3,500	4	5	2	0
3,600	4	5	6	0
3,700	4	5	4	0
3,800	4	7	4	0

Altitude	Reply code			
	A	B	C	D
3,900	4	7	6	0
4,000	4	7	2	0
4,100	4	7	3	0
4,200	4	7	1	0
4,300	4	3	1	0
4,400	4	3	3	0
4,500	4	3	2	0
4,600	4	3	6	0
4,700	4	3	4	0
4,800	4	2	4	0
4,900	4	2	6	0
5,000	4	2	2	0
5,100	4	2	3	0
5,200	4	2	1	0
5,300	4	6	1	0
5,400	4	6	3	0
5,500	4	6	2	0
5,600	4	6	6	0
5,700	4	6	4	0
5,800	4	4	4	0
5,900	4	4	6	0
6,000	4	4	2	0
6,100	4	4	3	0
6,200	4	4	1	0
6,300	4	0	1	0
6,400	4	0	3	0
6,500	4	0	2	0
6,600	4	0	6	0
6,700	4	0	4	0
6,800	6	0	4	0
6,900	6	0	6	0
7,000	6	0	2	0
7,100	6	0	3	0
7,200	6	0	1	0
7,300	6	4	1	0
7,400	6	4	3	0
7,500	6	4	2	0
7,600	6	4	6	0
7,700	6	4	4	0
7,800	6	6	4	0
7,900	6	6	6	0
8,000	6	6	2	0
8,100	6	6	3	0
8,200	6	6	1	0
8,300	6	2	1	0
8,400	6	2	3	0
8,500	6	2	2	0
8,600	6	2	6	0
8,700	6	2	4	0
8,800	6	3	4	0
8,900	6	3	6	0
9,000	6	3	2	0
9,100	6	3	3	0
9,200	6	3	1	0
9,300	6	7	1	0
9,400	6	7	3	0
9,500	6	7	2	0
9,600	6	7	6	0
9,700	6	7	4	0
9,800	6	5	4	0
9,900	6	5	6	0
10,000	6	5	2	0

Altitude	Reply code			
	A	B	C	D
10,100.....	6	5	3	0
10,200.....	6	5	1	0

(5) Press the test set PUSH TO TEST switch. The ACCEPT indicator should light. If the REJECT indicator lights, set the altitude one increment (100 feet) above and below the test setting. An accept condition indicates the transponder set reply is normal; this action accounts for the normal deviations of the altitude digitizer.

*f. AN/APX-72 Mode 4 Tests.*

**CAUTION**

When using the AN/APM-123(V) for testing MODE 4, be sure that the REJECT light comes on momentarily before the ACCEPT light after depressing the PUSH TO TEST button. If only the ACCEPT light comes on, the transponder test set is defective. Refer it to a higher maintenance category for repair. IT IS POSSIBLE THAT THE AN/APX-72 MAY BE DEFECTIVE IN MODE 4 IF THE REJECT LIGHT DOES NOT COME ON BEFORE THE ACCEPT LIGHT ON THE AN/APM-123(V)(\*).

(1) Prepare equipment for operation in accordance with instructions in paragraph 2-7.

(2) Apply power to the AN/APX-72.

(3) Connect Interrogator Computer KIR-1A/TSEC to test set MODE 4 connector using cable CX-12216/APM-123(V). On the test set, place the MODE switch to MODE 4. ZEROIZE light on the test set should light.

(4) Using Code Changer Key KIK-18/TSEC, key the KIR-1A/TSEC and close the access door. ZEROIZE light on the test set should go out.

(5) Install Computer KIT-LA/TSEC in the aircraft.

(6) Turn the MASTER switch on Transponder Set Control C-6280A(P)/APX to STBY.

**NOTE**

Equipment must be in STANDBY for at least 2 minutes after power is applied.

(7) Connect headset to aircraft intercom system.

(8) Set the controls on the C-6280A (P)/APX as follows:

<i>Control</i>	<i>Position</i>
MASTER.....	NORM
TEST M-1/OUT.....	OUT
TEST M-2/OUT.....	OUT
TEST M-3/OUT.....	OUT
TEST MC/OUT.....	OUT
AUDIO/OUT/LIGHT.....	AUDIO
CODE.....	A
MODE 4 ON/OUT.....	OUT

(9) On the test set, place the FUNCTION switch to SYSTEM, the MODE 4 DIR/RAD switch to DIR, the

MODE 4 code A/B switch to A and the PUSH TO TEST switch to the LOCK position, and (when operating the test set) observe the following

(a) On the test set, the REJECT light should light.

(b) Audio tone should be heard in headset.

(c) IFF CAUTION light located on aircraft instrument panel should light.

(10) Using KIK-18/TSEC key the KIT-1A/TSEC and close access door. Observe same indications listed in (9) above. Release PUSH TO TEST switch.

(11) On C-6280A(P)/APX, place the MODE 4 switch to ON.

(12) On the test set, briefly depress the PUSH TO TEST switch and observe the following

(a) On the test set, first the REJECT light comes on and then the ACCEPT light.

(b) On the C-6280A(P)/APX, the REPLY light should light.

(c) Audio tone should be heard in headset.

(d) Aircraft IFF CAUTION light should be off.

(13) On the C-6280A(P)/APX, place the AUDIO/LIGHT switch to the LIGHT position, and repeat the above test. Audio tone should not be heard, but REPLY light should light.

(14) On the test set, place the MODE 4 CODE A/B switch to B and briefly depress the PUSH TO TEST button. The REJECT light should come on and stay on. Return MODE 4 CODE A/B switch to A.

(15) On the test set, place the MODE 4 VER BIT 1 switch to 1 and briefly depress the PUSH TO TEST switch. The REJECT light shall light and remain lighted.

(16) On the C-6280A(P)/APX hold the RAD TEST-MON switch in the RAD TEST position and repeat test in (15) above. The REJECT light should come on momentarily and then the ACCEPT light. Return MODE 4 VER BIT 1 switch to OFF.

(17) On the test set, place the MODE 4 VER BIT 2 switch to 2 and briefly depress the PUSH TO TEST switch. The REJECT light should light. Return MODE 4 VER BIT 2 switch to OFF.

(18) On the test set, place the ISLS switch to ON and briefly depress the PUSH TO TEST switch. The REJECT light should light. Return ISLS switch to OFF.

(19) On aircraft with rigid landing gear, set IFF CODE HOLD switch located on aircraft instrument panel to ON. IFF CODE HOLD light located on aircraft instrument panel should light. On aircraft with compression or retractable landing gear, make certain landing gear is in a stable condition so that the automatic IFF CODE HOLD switch on landing gear is activated and remains so.

(20) On C-6280A(P)/APX, place CODE switch to HOLD, then return to A.

(21) Wait at least 15 seconds and then on the C-6280A(P)/APX turn MASTER switch to OFF.

(22) Wait at least 15 seconds and then on the C-6280A(P)/APX turn MASTER switch to STBY for a warmup of about 30 seconds; then turn MASTER switch to NORM.

**NOTE**

To assure the KIT/SEC will zeroize when power is interrupted or removed, IFF hold switch should always be in the OFF position unless test or flight procedures require going into code hold operation.

(23) On the test set, briefly depress PUSH TO TEST switch. The REJECT light should come on momentarily, then the ACCEPT.

(24) On the C-6280A(P)/APX pull out CODE switch and turn to ZERO, and place AUDIO/LIGHT switch to AUDIO position.

**NOTE**

Subparagraph (4) will be performed only if the aircraft is to go on operational status.

(24.1) After performing the above test, using KIK-18/TSEC Code Changer, rekey the KIT/TSEC and

close access door ensuring main power is still on the aircraft. Verify the key by performing the procedures in (12) above.

(25) On the test set, place the PUSH TO TEST switch to LOCK position, and observe the following.

(a) On the test set the REJECT light should light.

(b) Audio tone should be heard in the headset.

(c) IFF CAUTION light located on aircraft instrument panel should light.

(26) Return CODE switch on C-6280A(P)/APX to the A position.

**2-11. Stopping Procedure**

a. To stop the test set, release the PUSH TO TEST switch if it is in the LOCK position and set the 28VDC-115VAC-OFF power switch to OFF.

b. On aircraft with rigid landing gear, set IFF CODE HOLD switch located on aircraft instrument panel to OFF.

c. On transponder set control C-6280A(P)/APX turn MASTER switch to OFF. Open the access door to the KIR/TSEC is zeroized. Close access door.



## CHAPTER 3

### MAINTENANCE INSTRUCTIONS

---

#### 3-1. Scope of Maintenance

The maintenance duties assigned to the operator of the test set are listed below, together with a reference to the paragraphs covering the specific maintenance functions. These procedures do not require special tools or test equipment other than those allocated.

- a. Daily preventive maintenance checks and services (para 3-5).
- b. Monthly preventive maintenance checks and services (para 3-6).
- c. Quarterly preventive maintenance checks and services (para 3-7).
- d. Cleaning (para 3-8).
- e. Touchup painting (para 3-9).
- f. Replacement of lamps (para 3-12).
- g. Replacement of fuses (para 3-13).

#### 3-2. Tools and Materials Required for Maintenance

The tools and materials required for operator and organizational maintenance are as follows:

- a. Tool Kit, Electronic Equipment TK-101/G.
- b. Trichloroethane.
- c. Cleaning cloth.
- d. Soft-bristled brush.
- e. Sandpaper, extra, fine, #000.

#### 3-3. Preventive Maintenance

Preventive maintenance is the systematic care, servicing, and inspection of equipment to prevent the occurrence of trouble, to reduce out-of-service time, and to assure that the equipment is serviceable.

a. *Systematic Care.* The procedures given in paragraphs 3-4 through 3-8 cover routine systematic care and cleaning essential to proper upkeep and operation of the test set.

b. *Preventive Maintenance Checks and Services.* The preventive maintenance checks and services charts (para 3-5, 3-6, and 3-7) outline the functions to be performed at specific intervals. These checks and services are to maintain electronic equipment in a combat-serviceable condition; that is, in good general (physical) condition and in good operating condition. To assist operators in maintaining combat serviceability, the charts indicate what to check, how to check, and the normal conditions; the References column lists the paragraphs or manuals that contain detailed repair or replacement procedures. If the defect cannot be remedied by performing the corrective action indicated, higher level maintenance or repair is required. Records and reports of these checks and services must be made in accordance with the requirements set forth in TM 38-750.

#### 3-4. Preventive Maintenance Checks and Service Periods

Preventive maintenance service and inspections of the test set are required on a daily, monthly, and quarterly basis. Paragraph 3-5 specifies preventive maintenance checks and services that must be performed daily (if not in standby condition) and under the special following conditions:

- a. Before the test set is installed for operation.
- b. When the equipment is returned after higher level of repair.
- c. At least once each week if the equipment is maintained in a standby condition.

### 3-5. Daily Preventive Maintenance Checks and Services Chart

<i>Sequence No.</i>	<i>Item</i>	<i>Procedure</i>	<i>References</i>
<b>POWER OFF INSPECTION</b>			
1	Completeness	See that the equipment is complete.	Para 1-7
2	Exterior items	Check for looseness of exterior items, such as connectors, switches, and latches. Tighten all loose mounting screws and nuts	
3	Knobs and switches	Check to see that mechanical action of switches and knobs is smooth, and free of binding and scraping.	
4	Operation	During operation, be alert for unusual or faulty operation.	
<b>POWER ON INSPECTION</b>			
5	Preliminary	a. Connect the power cable between the POWER connector and the power source. b. Set the FUNCTION switch to SELF TEST. c. Set the 28 VDC-115 VAC-OFF power switch to 28 VDC or 115 VAC as applicable. d. Allow two minutes warm-up time.	
6	ACCEPT indicator	Press the ACCEPT indicator to see that the indicator lights.	Para 3-11
7	REJECT indicator	Press the REJECT indicator to see that the indicator lights.	Para 3-11
8	MODE switch and PUSH TO TEST switch	Set the MODE switch to TEST and press the PUSH TO TEST switch to see that the ACCEPT indicator lights	Para 3-11

### 3-6. Monthly Maintenance Checks and Services Chart

<i>Sequence No.</i>	<i>Item</i>	<i>Procedure</i>	<i>References</i>
1	Cables	Check cables for breaks, cuts, kinks, fraying, and broken connectors; replace defective cables.	
2	Connectors	Inspect connectors for snug fit and good contacts.	
3	Handles, latches, and hinges	Check handles, latches, and hinges for looseness and defects.	
4	Metal surfaces	Check all exposed metal surfaces for rust and corrosion. Clean and touch up paint as required.	Para 3-9

### 3-7. Quarterly Preventive Maintenance Checks and Services Chart

<i>Sequence No.</i>	<i>Item</i>	<i>Procedure</i>	<i>References</i>
1	Publications	Check to see that all pertinent publications are serviceable and current.	DA Pam 310-4 (Army), NAVSUP-2002 (Navy), TO 0-1-12 (Air Force).
2	Modification work orders	Check to determine if new applicable MWO'S have been published. ALL URGENT MWO'S must be applied immediately.	TM 33-750 and DA Pam 310-7 (Army), NAVSUP-2002 (Navy), TO 0-1-12 (Air Force).

### 3-8. Cleaning

Inspect the exterior of the test set. The exterior surfaces, including the front panel and antenna, should be clean and free of dust, dirt, grease, and fungus.

a. Remove dust and loose dirt with a clean, soft cloth.

b. Remove dirt from the connectors with a soft-bristled cloth or brush.

#### **WARNING**

The fumes of trichloroethane are toxic. Provide thorough ventilation whenever used. DO NOT use near an open flame. Trichloroethane is not flammable, but

exposure of the fumes to open flames converts the fumes to highly toxic, dangerous gases.

c. Remove grease, fungus, and ground-in dirt from cases; use a cloth dampened (not wet) with trichloroethane.

**CAUTION**

Do not apply excessive pressure to the antenna or damage to the antenna may result.

**3-9. Touchup Painting Inspections**

**NOTE**

Refer to the applicable cleaning and re-finishing practices specified in TB 746-10.

a. Remove rust and corrosion from metal surfaces by lightly sanding them with #000 sandpaper.

b. Brush two thin coats of paint (enamel, semi-gloss specification No. TT-E-529, FSN 8010-381-1242) on the bare metal to protect it from further corrosion.

**3-10. General Troubleshooting Information**

Troubleshooting this equipment is based on the operational check contained in the daily preventive maintenance checks and services chart. To troubleshoot the equipment, perform all functions starting with item 5 in the daily preventive maintenance checks and services chart (para 3-5) and proceed through the items until an abnormal condition or result is observed. Perform the checks and corrective actions indicated in the troubleshooting chart. If the corrective measures indicated do not result in correction of the trouble, higher level maintenance is required.

**3-11. Troubleshooting Chart**

<i>Item No.</i>	<i>Trouble symptom</i>	<i>Probable trouble</i>	<i>Checks and corrective measures</i>
1	POWER indicator does not light.	a. Power cable or POWER indicator lamp defective. b. Defective fuse.	a. Replace lamp (para 3-12). Replace power cable. b. Replace fuse (para 3-13).
2	ACCEPT or REJECT indicator does not light.	Lamp defective.	Replace lamp (para 3-12).
3	Self-test indicates REJECT.	Test set not operating properly.	Higher level maintenance required.

**3-12. Replacement of Lamps**

To remove and replace the lamps, proceed as follows :

- a. Rotate the indicator cap counterclockwise.
- b. Press the lamp in, rotate it counterclockwise, and remove it or withdraw lamp from indicator cap as applicable.
- c. Install a new lamp into the lamp socket or indicator cap.
- d. Tighten the indicator cap by rotating clockwise.

**3-13. Replacement of Fuses**

To remove and replace the fuses, proceed as follows :

- a. Rotate the fuse cap counterclockwise.
- b. Pull the defective fuse out of the fuse cap and install a good fuse.
- c. Install the 1 new fuse cap back in the test set; tighten the fuse cap by rotating clockwise.



## APPENDIX A

### REFERENCES

---

Following is a list of references available to the operator and organizational maintenanceman of the test set.

- |              |  |
|--------------|--|
| DA Pam 310-4 | Military Publications: Index of Technical Manuals, Technical Bulletins, Supply Manuals (types 7, 8, and 9), Supply Bulletins and Lubrication Orders. |
| DA Pam 310-7 | Military Publications: US Army Equipment Index of Modification Work Orders.  |
| SB 11-573    | Painting and Preservation Supplies Available for Field Use for Electronics Command Equipment.  |
| SB 38-100    | Preservation, Packaging, Packing and Marking Materials, Supplies and Equipment Used by the Army.   |
| TB 746-10    | Field Instructions for Painting and Preserving Electronics Command Equipment.  |
| TM 38-750    | The Army Maintenance Management System (TAMMS).  |
| TM 740-90-1  | Technical Manual: Administrative Storage of Equipment.   |
| TM 750-244-2 | Technical Manual: Procedures for Destruction of Electronics Material to Prevent Enemy Use (Electronics Command).                                     |



## APPENDIX B

### MAINTENANCE ALLOCATION (Army only)

---

#### Section 1. INTRODUCTION

#### **B-1. General**

This appendix provides a summary of the maintenance operations covered in the equipment literature. It authorizes categories of maintenance for specific maintenance functions on repairable items and components and the tools and equipment required to perform each function. This appendix may be used as an aid in planning maintenance operations.

#### **B-2. Maintenance Functions**

Maintenance functions will be limited to and defined as follows:

- a. Inspect.* To determine serviceability of an item by comparing its physical, mechanical, and electrical characteristics with established standards.
- b. Test.* To verify serviceability and to detect incipient electrical or mechanical failure by use of special equipment such as gages, meters, etc. This is accomplished with external test equipment and does not include operation of the equipment and operator type tests using internal meters or indicating devices.
- c. Service.* To clean, to preserve, to charge, and to add fuel, lubricants, cooling agents, and air. If it is desired that elements, such as painting and lubricating, be defined separately, they may be so listed.
- d. Adjust.* To rectify to the extent necessary to bring into proper operating range.
- e. Align.* To adjust two or more components or assemblies of an electrical or mechanical system so that their functions are properly synchronized. This does not include setting the frequency control knob of radio receivers or transmitters to the desired frequency.
- f. Calibrate.* To determine the corrections to be made in the readings of instruments or test equipment used in precise measurement. Consists of the comparison of two instruments, one of which is a certified standard of known accuracy, to detect and adjust any discrepancy in the accuracy of the instrument being compared with the certified standard.
- g. Install.* To set up for use in an operational environment such as an encampment, site, or vehicle.
- h. Replace.* To replace unserviceable items with serviceable like items.
- i. Repair.* To restore an item to serviceable condition through correction of a specific failure or unserviceable condition. This function includes, but is not limited to welding, grinding, riveting, straightening, and replacement of parts other than by the trial and error replacement of running spare type items such as fuses, lamps, or electron tubes.
- j. Overhaul.* Normally, the highest degree of maintenance performed by the Army in order to minimize time work in process is consistent with quality and economy of operation. It consists of that maintenance necessary to restore an item to completely serviceable condition as prescribed by maintenance standards in technical publications for each item of equipment. Overhaul normally does not return an item to like new, zero mileage, or zero hour condition.
- k. Rebuild.* The highest degree of materiel maintenance. It consists of restoring equipment as nearly as possible to new condition in accordance with original manufacturing standards. Rebuild is performed only when required by operational considerations or other paramount factors and then only at the depot maintenance category. Rebuild reduces to zero the hours or miles the equipment, or component thereof, has been in use.
- l. Symbols.* The uppercase letter placed in the appropriate column indicates the lowest level

at which that particular maintenance function is to be performed.

**B-3. Explanation of Format**

a. *Column 1, Group Number.* Not applicable.

b. *Column 2, Functional Group.* Column 2 lists the noun names of components, assemblies, sub-assemblies, and modules on which maintenance is authorized.

c. *Column 3, Maintenance Functions.* Column 3 lists the maintenance category at which performance of the specific maintenance function is authorized. Authorization to perform a function at any category also includes authorization to perform that function at higher categories. The codes used represent the various maintenance categories as follows:

<i>code</i>	<i>Maintenance category</i>
C	Operator/crew
O	Organizational maintenance
F	Direct support maintenance
H	General Support Maintenance
D	Depot maintenance

d. *Column 4, Tools and Test Equipment.* Column 4 specifies, by code, those tools and test equipment required to perform the designated

function. The numbers appearing in this column refer to specific tools and test equipment which are identified in table I.

e. *Column 5, Remarks.* Self-explanatory.

**B-4. Explanation of Format of Table 1, Tool and Test Equipment Requirements**

The columns in table I are as follows:

a. *Tool and Equipment.* The numbers in this column coincide with the numbers used in the Tools and equipment column of the maintenance allocation chart. The numbers indicate the applicable tool for the maintenance function.

b. *Maintenance Category.* The codes in this column indicate the maintenance category normally allocated the facility.

c. *Nomenclature.* This column lists tools, test, and maintenance equipment required to perform the maintenance functions.

d. *Federal Stock Number.* This column lists the Federal stock number of the specific tool or test equipment.

e. *Tool Number.* Not used.



**Section II. MAINTENANCE ASSIGNMENT**

Group Number	Component Assembly Nomenclature	Maintenance Functions											Tools and Equipment	Remarks		
		Inspect	Test	Service	Adjust	Align	Calibrate	Install	Replace	Repair	Overhaul	Rebuild				
	Test Set, Transponder AN/APM-123(V)1	O	O												4	Visual inspection Verify operation, cables, fuses, lamps Clean cables, surfaces Fuses, knobs, lamps, flush mounted antenna and cables. Operation RF transmitter to insure proper power output and correct frequency. Piece Parts.
				O											14	
			H												1, 2-5, 7, 9-11, 13, 15-21 1, 3, 5, 10, 13, 15, 17 18, 19, 20, 21	
														H	6, 12 1-8, 10-13, 15-21	

Table 1. Tool and Test Equipment Requirements

Tools and Equipment	Maintenance Category	Nomenclature		FSN	Tool Number
1	H,D	Generator, Signal	AN/URM-64	6625-570-5721	
2	D	Crystal Adapter	UG-119/UP	5960-186-7764	
3	H,D	Multimeter	ME-26A/U	6625-646-9409	
4	O,H,D	Multimeter	AN/USM-223	6625-999-7465	
5	H,D	Oscilloscope	AN/USM-281A	6625-228-2201	
6	H,D	Repair Kit, Printed Wiring Board	MK-772( )/U	5999-757-7042	
7	H,D	Test Set, Crystal Unit, Quartz	TS-268E/U	6625-669-1215	
8	D	Test Set Electron Tube	TV-2/U	6625-669-0263	
9	H	Test Set, Electron Tube	TV-7D/U	6625-820-0064	
10	H,D	Test Set, Radar	AN/UPM-98A	6625-912-0429	
11	H,D	Test Set, Semiconductor Device	TS-1836/U	6625-893-2628	
12	H,D	Tool Kit, Electronic Equipment	TK-100/G	5180-605-0079	
13	H,D	Wattmeter	AN/URM-98	6625-566-4990	
14	O	Tool Kit, Electronic Equipment	TK-101/G	5180-064-5178	
15	H,D	Modulator	MD-796/U	6625-490-6817	
16	H,D	Test Facilities Set, Transponder Test Set	AN/APM-270(V)	6625-888-4589	
17	H,D	Counter Electronic Digital Readout	AN/USM-207	6625-911-6368	
18	H,D	Comparator, Frequency	CM-77/USM	6625-788-3780	
19	H,D	Plug-in Unit, Dual Trace Oscilloscope	PL-1186A/USM	6625-234-6117	
20	H,D	Plug-in Unit, Time Base and Delay, Oscilloscope	PL-1187A/USM	6625-410-2406	
21	H,D	Detector; Microlab XA-0640 detector Mount w/diode 1N21WE			





THEN... JOT DOWN THE DOPE ABOUT IT ON THIS FORM, CUT IT OUT, FOLD IT AND DROP IT IN THE MAIL!

# SOMETHING WRONG WITH THIS MANUAL?

FROM: (YOUR UNIT'S COMPLETE ADDRESS)

DATE

PUBLICATION NUMBER

DATE

BE EXACT... PIN-POINT WHERE IT IS

IN THIS SPACE TELL WHAT IS WRONG

PAGE NO.	PARA-GRAPH	FIGURE NO.	TABLE NO.
----------	------------	------------	-----------

CUT ALONG DOTTED LINE

TYPED NAME, GRADE OR TITLE AND TELEPHONE NUMBER

SIGN HERE:

DA FORM 2028-2 (TEST)  
1 AUG 74

P.S.--IF YOUR OUTFIT WANTS TO KNOW ABOUT YOUR MANUAL "FIND," MAKE A CARBON COPY OF THIS AND GIVE IT TO YOUR HEADQUARTERS.

FILL IN YOUR  
UNIT'S ADDRESS

FOLD BACK

DEPARTMENT OF THE ARMY

---

---

OFFICIAL BUSINESS  
PENALTY FOR PRIVATE USE \$300

POSTAGE AND FEES PAID  
DEPARTMENT OF THE ARMY  
DOD 314



Commander  
US Army Electronics Command  
ATTN: AMSEL-MA-Q  
Fort Monmouth, NJ 07703

CUT ALONG DOTTED LINE

FOLD BACK

RECOMMENDED CHANGES TO EQUIPMENT TECHNICAL MANUALS



# SOMETHING WRONG WITH THIS MANUAL?

THEN... JOT DOWN THE DOPE ABOUT IT ON THIS FORM, CUT IT OUT, FOLD IT AND DROP IT IN THE MAIL!

FROM: (YOUR UNIT'S COMPLETE ADDRESS)

DATE

PUBLICATION NUMBER

DATE

BE EXACT... PIN-POINT WHERE IT IS

IN THIS SPACE TELL WHAT IS WRONG

PAGE NO.	PARA-GRAPH	FIGURE NO.	TABLE NO.
----------	------------	------------	-----------

CUT ALONG DOTTED LINE

TYPED NAME, GRADE OR TITLE, AND TELEPHONE NUMBER

SIGN HERE:

DA FORM 2028-2 (TEST)  
1 AUG 74

P.S.--IF YOUR OUTFIT WANTS TO KNOW ABOUT YOUR MANUAL "FIND," MAKE A CARBON COPY OF THIS AND GIVE IT TO YOUR HEADQUARTERS.

FILL IN YOUR  
UNIT'S ADDRESS



FOLD BACK

DEPARTMENT OF THE ARMY

---

---

OFFICIAL BUSINESS  
PENALTY FOR PRIVATE USE \$300

POSTAGE AND FEES PAID  
DEPARTMENT OF THE ARMY  
DOD 314



Commander  
US Army Electronics Command  
ATTN: AMSEL-MA-Q  
Fort Monmouth, NJ 07703

CUT ALONG DOTTED LINE

FOLD BACK

REVERSE OF DA FORM 2028-2 (TEST)

RECOMMENDED CHANGES TO EQUIPMENT TECHNICAL MANUALS



# SOMETHING WRONG WITH THIS MANUAL?

THEN... JOT DOWN THE DOPE ABOUT IT ON THIS FORM, CUT IT OUT, FOLD IT AND DROP IT IN THE MAIL!

FROM: (YOUR UNIT'S COMPLETE ADDRESS)

DATE

PUBLICATION NUMBER

DATE

BE EXACT... PIN-POINT WHERE IT IS

IN THIS SPACE TELL WHAT IS WRONG

PAGE NO.

PARA-GRAPH

FIGURE NO.

TABLE NO.

CUT ALONG DOTTED LINE

TYPED NAME, GRADE OR TITLE, AND TELEPHONE NUMBER

SIGN HERE:

DA FORM 2028-2 (TEST)  
1 AUG 74

P.S.--IF YOUR OUTFIT WANTS TO KNOW ABOUT YOUR MANUAL "FIND," MAKE A CARBON COPY OF THIS AND GIVE IT TO YOUR HEADQUARTERS.

FILL IN YOUR  
UNIT'S ADDRESS

DEPARTMENT OF THE ARMY

OFFICIAL BUSINESS  
PENALTY FOR PRIVATE USE \$300

FOLD BACK

POSTAGE AND FEES PAID  
DEPARTMENT OF THE ARMY  
DOD 314



Commander  
US Army Electronic Command  
ATTN: AMSEL-MA-Q  
Fort Monmouth, NJ 07703

CUT ALONG DOTTED LINE

FOLD BACK

REVERSE OF DA FORM 2028-2 (TEST)



By Order of the Secretary of the Army:

CREIGHTON W. ABRAMS  
*General, United States Army*  
*Chief of Staff*

Official:

VERNE L. BOWERS  
*Major General, United States Army*  
*The Adjutant General*

Published Under Authority of the Secretaries of the Navy and the Air Force.

**DISTRIBUTION:**

To be distributed in accordance with DA Form 12-36A (qty rqr block no. 684), Organizational maintenance requirements for AN/APM-123.





